

CA Building Products

Evenwood Industrial Estate
Copeland Road
Evenwood
Co Durham DL14 9SF
Tel: 01388 834242 Fax: 01388 834711
e-mail: help@cagroup.ltd.uk
website: www.cagroup.ltd.uk



Agrément Certificate
07/4428
Product Sheet 1

CA BUILDING PRODUCTS ROOF SYSTEMS

TWIN-THERM ROOF SYSTEM

PRODUCT SCOPE AND SUMMARY OF CERTIFICATE

This Certificate relates to the Twin-Therm Roof System, a structural roofing system for use in industrial, commercial, retail and leisure applications and in residential and non-residential buildings such as schools and hospitals. The system is suitable for roofs with a finished fall of between 3° and 60° and on curved roofs with radii between 45 m and 130 m where access is restricted to maintenance and repair only.

AGRÉMENT CERTIFICATION INCLUDES:

- factors relating to compliance with Building Regulations where applicable
- factors relating to additional non-regulatory information where applicable
- independently verified technical specification
- assessment criteria and technical investigations
- design considerations
- installation guidance
- regular surveillance of production
- formal three-yearly review.



KEY FACTORS ASSESSED

Structural performance — when installed and used in accordance with this Certificate, the Twin-Therm roof system will have sufficient strength and stiffness to resist the wind and imposed loads likely to be experienced in the UK (see section 5).

Weathertightness — when installed in accordance with the manufacturer's instructions and this Certificate, the system will be weathertight within the specified exposure conditions and when used on roofs with finished slopes of between 3° and 60° (see sections 5 and 6).

Thermal performance — the system can contribute to meeting the requirements of the national Building Regulations (see section 7).

Risk of condensation — provided that installation has been carried out correctly and the vapour control layers and liners remain undamaged, the risks of surface and interstitial condensation under normal conditions will be negligible (see section 8).

Airtightness — a building incorporating the system will remain reasonably airtight provided that the integrity of the sealing of the liner and vapour control layer is maintained and that other building elements have incorporated appropriate design details and building techniques to prevent air permeability (see section 9).

Performance in relation to fire — the profiled sheets have a notional designation national class/European class of AA/B_{ROOF}(t4) ('low vulnerability' in Scotland) and the liner sheets have a Class 0 or 'low risk' internal surface spread of flame classification (see section 10).

The BBA has awarded this Agrément Certificate to the company named above for the system described herein. This system has been assessed by the BBA as being fit for its intended use provided it is installed, used and maintained as set out in this Certificate.

On behalf of the British Board of Agrément

Brian Chamberlain

Head of Approvals — Engineering

Greg Cooper

Chief Executive

Date of First issue: 14 June 2011

Originally certificated on 21 May 2007

The BBA is a UKAS accredited certification body — Number 113. The schedule of the current scope of accreditation for product certification is available in pdf format via the UKAS link on the BBA website at www.bbacerts.co.uk

Readers are advised to check the validity and latest issue number of this Agrément Certificate by either referring to the BBA website or contacting the BBA direct.

British Board of Agrément
Bucknalls Lane
Garston, Watford
Herts WD25 9BA

©2011

tel: 01923 665300
fax: 01923 665301
e-mail: mail@bba.star.co.uk
website: www.bbacerts.co.uk

Regulations

In the opinion of the BBA, the Twin-Therm Roof System, if used in accordance with the provisions of this Certificate, will meet or contribute to meeting the relevant requirements of the following Building Regulations:



The Building Regulations 2010 (England and Wales)

Requirement: A1	Loading
Comment:	The system has sufficient strength and stiffness to sustain and transmit the design loads in accordance with sections 5.1 to 5.5 of this Certificate.
Requirement: B2(1)	Internal fire spread (linings)
Comment:	The exposed surfaces (as seen from inside the building) of the liner sheets are unrestricted under this Requirement. See sections 10.1 and 10.3 to 10.5 of this Certificate.
Requirement: B4(2)	External fire spread
Comment:	The external surface of the roofing sheets is unrestricted under this Requirement. See sections 10.1 and 10.3 to 10.5 of this Certificate.
Requirement: C2(b)	Resistance to moisture
Comment:	When installed in accordance with this Certificate and subjected to the maximum design loads given in section 5, the system will resist the passage of moisture to the inside of the building. See sections 6.1 and 6.2 of this Certificate.
Requirement: C2(c)	Resistance to moisture
Comment:	The system poses minimal risk of harmful effects on the building and its occupants arising from interstitial and surface condensation. See sections 8.1 to 8.6 of this Certificate.
Requirement: L1(a)(i)	Conservation of fuel and power
Comment:	When used with an adequate thickness of insulation and provided appropriate measures are taken to counteract thermal bridging effects, the system can meet or contribute to a construction meeting the U values given in the relevant tables of the Approved Documents. See sections 7.1 to 7.4, 9.1 and 9.2 of this Certificate.
Requirement: Regulation 7	Materials and workmanship
Comment:	The system is acceptable. See sections 13.1 and 13.2 and the <i>Installation</i> part of this Certificate.



The Building (Scotland) Regulations 2004 (as amended)

Regulation: 8(1)(2)	Fitness and durability of materials and workmanship
Comment:	Use of the system satisfies the requirements of this Regulation. See sections 12.1 to 12.3, 13.1 and 13.2 and the <i>Installation</i> part of this Certificate.
Regulation: 9	Building Standards – construction
Standard: 1.1(a)(b)	Structure
Comment:	The system has sufficient strength and stiffness to transmit the design load, with reference to clauses 1.1.2 ⁽¹⁾⁽²⁾ and 1.1.3 ⁽¹⁾⁽²⁾ . See sections 5.1 to 5.5 of this Certificate.
Standard: 2.1	Compartmentation
Comment:	The roof finishing details on the internal side of the system have been assessed as having a 'low vulnerability' classification, with reference to clause 2.1.15 ⁽²⁾ . See sections 10.2 to 10.5 of this Certificate.
Standard: 2.2	Separation
Comment:	The roof covering has been assessed as having a 'low vulnerability' classification, with reference to clauses 2.2.10 ⁽¹⁾ , 2.2.7 ⁽²⁾ and 2.1.15 ⁽²⁾ . See sections 10.2 to 10.5 of this Certificate.
Standard: 2.5	Internal linings
Comment:	The ceiling surfaces (as seen from inside the building) have been assessed as having a 'low vulnerability' classification, with reference to clause 2.5.1 ⁽¹⁾⁽²⁾ . See sections 10.2 to 10.5 of this Certificate.
Standard: 2.8	Spread from neighbouring buildings
Comment:	The external roofing sheets have a 'low vulnerability' classification and are not restricted by this Standard, with reference to clause 2.8.1 ⁽¹⁾⁽²⁾ . See sections 10.2 to 10.5 of this Certificate.
Standard: 3.10	Precipitation
Comment:	When subjected to the maximum design load given in this Certificate, the system will resist the passage of moisture to the inside of the building, with reference to clause 3.10.1 ⁽¹⁾⁽²⁾ . See sections 6.1 and 6.2 of this Certificate.
Standard: 3.15	Condensation
Comment:	The system will have minimal risk of surface condensation or of damage due to interstitial condensation, with reference to clauses 3.15.1 ⁽¹⁾⁽²⁾ , 3.15.2 ⁽¹⁾⁽²⁾ , 3.15.3 ⁽¹⁾⁽²⁾ , 3.15.4 ⁽¹⁾⁽²⁾ and 3.15.5 ⁽¹⁾⁽²⁾ . See sections 8.1 to 8.6 of this Certificate.
Standard: 6.1(b)	Carbon dioxide emissions
Standard: 6.2	Building insulation envelope
Comment:	The system can meet or contribute to a construction meeting the U values given in clauses 6.1.1 ⁽¹⁾⁽²⁾ , 6.1.2 ⁽¹⁾⁽²⁾ , 6.1.3 ⁽¹⁾⁽²⁾ , 6.1.4 ⁽²⁾ , 6.1.6 ⁽¹⁾ , 6.1.7 ⁽¹⁾ , 6.2.1 ⁽¹⁾⁽²⁾ , 6.2.3 ⁽¹⁾ , 6.2.4 ⁽¹⁾⁽²⁾ , 6.2.5 ⁽²⁾ , 6.2.6 ⁽²⁾ , 6.2.7 ⁽¹⁾⁽²⁾ , 6.2.9 ⁽¹⁾⁽²⁾ and 6.2.13 ⁽¹⁾⁽²⁾ . See sections 7.1 to 7.4, 9.1 and 9.3 of this Certificate.

(1) Technical Handbook (Domestic).

(2) Technical Handbook (Non-Domestic).



The Building Regulations (Northern Ireland) 2000 (as amended)

Regulation:	B2	Fitness of materials and workmanship
Comment:		The system is acceptable. See sections 13.1 and 13.2 and the <i>Installation</i> part of this Certificate.
Regulation:	B3(2)	Suitability of certain materials
Comment:		The system is acceptable. See sections 12.1 to 12.3 of this Certificate.
Regulation:	C4(b)	Resistance to ground moisture and weather
Comment:		When subjected to the maximum design load given in this Certificate, the system will resist the passage of moisture to the inside of the building. See sections 6.1 and 6.2 of this Certificate.
Regulation:	C5	Condensation
Comment:		The risk of harmful effects on the building due to interstitial condensation within the system will be minimal. See sections 8.1 to 8.6 of this Certificate.
Regulation:	D1	Stability
Comment:		The system has sufficient strength and stiffness to sustain and transmit the design loads in accordance with sections 5.1 to 5.5 of this Certificate.
Regulation:	E3(a)	Internal fire spread – Linings
Regulation:	E5(b)	Internal fire spread
Comment:		The system is unrestricted under this Regulation. See sections 10.1 and 10.3 to 10.5 of this Certificate.
Regulation:	F2(a)(i)	Conservation measures
Regulation:	F3(2)	Target carbon dioxide Emissions Rate
Comment:		The system can meet or contribute to a construction meeting the U values given in sections 7.1 to 7.4, 9.1 and 9.4 of this Certificate.

Construction (Design and Management) Regulations 2007

Construction (Design and Management) Regulations (Northern Ireland) 2007

Information in this Certificate may assist the client, CDM co-ordinator, designer and contractors to address their obligations under these Regulations.

See sections: 2 *Delivery and site handling* (2.1 and 2.2) and 14 *General* (14.3) of this Certificate.

Non-regulatory Information

NHBC Standards 2011

NHBC accepts the use of the Twin-Therm Roof System, when installed and used in accordance with this Certificate, in relation to *NHBC Standards, Part 7 Roofs, Chapter 7.2 Pitched roofs*.

General

This Certificate relates to the Twin-Therm Roof System, a structural roofing intended to be fixed to steel, concrete or timber purlins.

The product is weathertight and structurally stable within the limits set out in this Certificate.

Twin-Therm is a registered trademark.

The Certificate holder has taken the responsibility of CE marking the profiled sheets in association with harmonised standard BS EN 14782 : 2006 and the insulation with harmonised standards BS EN 13162 : 2008 and BS EN 13172 : 2008 against which conformity is being declared.

Technical Specification

1 Description

1.1 The Twin-Therm Roof System is a roof covering of overlapping profiled sheets fixed, via a bar and bracket spacer and lining system, to the roof purlins. Through-fixing of the external roof sheeting is required.

1.2 Standard profiled sheets may be used on curved roofs with a minimum curve radius of 45 m. Pre-curved profiled sheets are required for radii of between 20 m and 45 m.

1.3 Each component is manufactured and supplied to a specification by the Certificate holder. The roof system comprises:

- CA 32 1000R profiled external sheets (see Figure 1) — 0.7 mm thick (nominal) profiled steel sheets available with coatings of:
 - Colorcoat HPS200⁽¹⁾ Ultra (200 µm thick) on zinc/aluminium alloy coated steel, manufactured to BS EN 10346 : 2009 (see BBA Certificate 91/2717, Product Sheet 8)
 - Colorcoat Prisma⁽¹⁾ (50 µm thick) on zinc/aluminium alloy coated steel, manufactured to BS EN 10346 : 2009 (see BBA Certificate 91/2717, Product Sheet 2)

- Colorcoat LG⁽¹⁾ (200 µm thick) on galvanized steel, manufactured to BS EN 10346 : 2009 (see BBA Certificate 91/2717, Product Sheet 3)
- Colorcoat Verso⁽¹⁾ (200 µm thick) on zinc/aluminium alloy coated steel, manufactured to BS EN 10346 : 2009 (see BBA Certificate 91/2717, Product Sheet 7)
- Colorcoat PVDF⁽¹⁾ (27 µm thick) on galvanized steel, manufactured to BS EN 10346 : 2009 (see BBA Certificate 91/2717, Product Sheet 4).

(1) Colorcoat HPS200 Ultra, Colorcoat Prisma, Colorcoat LG, Colorcoat Verso and Colorcoat PVDF are all registered trademarks of Tata Steel UK Limited.

Figure 1 CA 32 1000R profile

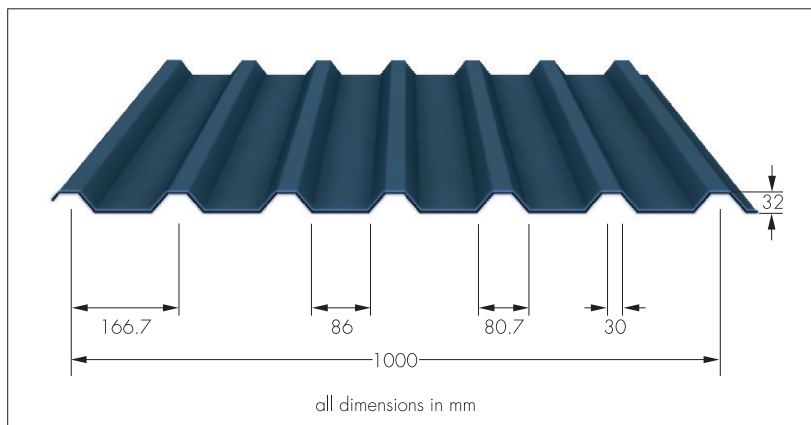

- external profile fixings and sealants, comprising:
 - fasteners, type CSSC 32/16 No 12, 32 mm long nylon-headed carbon steel with a zinc coating of 8 µm, self-drilling for fixing to mild steel up to 3.5 mm thick. The nylon head is injection-moulded into the head of the fastener. Below the head of the fastener is a 16 mm diameter, aluminium bonded washer with an integral seal of EPDM rubber to provide a seal at the connection. Alternatively, type CSSS 28/16 stainless steel fixings are used
 - Therma-strip 6x5 (6 mm by 5 mm) butyl strip sealant, used to seal side and end laps of type CA 32 1000R profile sheets
 - Therma-fill blocks, ventilated filler blocks used for partially closing ridge and eaves of external profiles. Polyethylene fillers used as standard or MP fillers used for extended guarantees and/or in coastal regions.
- profiled liner sheets, available in two types:
 - CA LT 17 1000S, manufactured from minimum 0.4 mm thick nominal galvanized steel, grade Fe E220G Z275, to BS EN 10346 : 2009. The reverse surface is finished with a two-coat primer/polyester system and the visible external surface with a 15 µm thick Colorcoat⁽¹⁾ PE15 (see Figure 2)
 - CA 32 1000RL, manufactured from 0.7 mm thick nominal galvanized steel, grade Fe E220G Z275, to BS EN 10346 : 2009. The reverse surface is finished with a two-coat primer/polyester system and the visible external surface with a 15 µm thick Colorcoat⁽¹⁾ PE15

(1) Colorcoat is a registered trademark of Tata Steel UK Limited.

Figure 2 Liner sheets

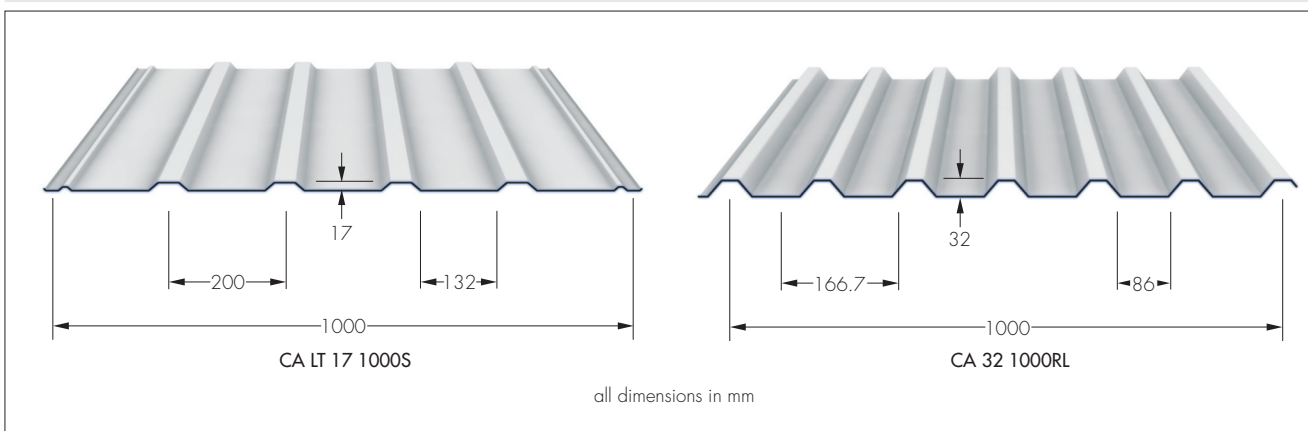

- liner profile fixings and sealants, comprising:
 - fasteners, type TSC20G19 No 12, 20 mm long carbon steel with a zinc coating of 8 µm, self-drilling with galvanized bonded washer to seal holes created by the fastener (to prevent moisture vapour from transferring via the fastener into the roof cavity). For purlins between 4 mm and 10 mm thick, a type TSL36G19 No 12 gauge, 36 mm long carbon steel with a zinc coating of 8 µm, self-drilling fastener with galvanized bonded washer is used

- sealant, either Therma-foil Plus (an aluminium foil tape incorporating a butyl sealant strip) to seal side laps or Therma-strip 9x3 or 6x5 (9 mm by 3 mm or 6 mm by 5 mm) butyl sealants to seal end laps
- solid flame-retarded polyethylene filler, 32 mm thick and manufactured to suit the liner panel.
- other accessories, comprising:
 - Matrix bar and bracket spacer system. The Matrix bar is manufactured from 1.5 mm thick galvanized steel, to BS EN 10346 : 2009, in lengths of typically 1200 mm or 3600 mm. The bracket is manufactured with 1.6 mm thick galvanized steel to BS EN 10346 : 2009, to heights from 80 mm to 300 mm in increments of 20 mm
 - knee-bracing, required at both end bays for brackets higher than 160 mm to give the Matrix bar greater stability. Manufactured from 2 mm thick galvanized steel to BS EN 10346 : 2009
 - Matrix bar and bracket spacer fixings — fasteners, type M27G16 No 12, 27 mm long carbon steel with a zinc coating of 8 µm, self-drilling with galvanized bonded washer to seal holes created by the fastener. For purlins between 4 mm and 10 mm thick, a type TSL36G19 No 12 gauge, 36 mm long carbon steel with a zinc coating of 8 µm, self-drilling fastener with galvanized bonded washer is used
 - Therma-quilt insulation, a non-hygroscopic glassfibre material available in rolls giving a cover width of 1200 mm without gaps between adjacent rolls. Various thicknesses are available (see Table 1).

Table 1 Therma-quilt insulation⁽¹⁾

Cavity depth (mm)	Therma-quilt type ⁽¹⁾ and thickness (mm)
80	TQ80
100	TQ100
120	TQ120
140	TQ140
160	TQ160
180	TQ180
200	TQ200
220	TQ220
240	TQ240
260	TQ260
280	TQ280
300	TQ300

(1) Normally supplied with a $\lambda_{90/90}$ value of 0.040 W·m⁻¹·K⁻¹ and compressed to suit the cavity.

1.4 The sequence of components for the system (see Figure 3) is (inner to outer):

- liner panels type CA LT 17 1000S or CA 32 1000RL (side laps sealed with Therma-foil Plus, end laps sealed with relevant Therma-strip as detailed in section 1.3) with solid flame-retarded polyethylene fillers at eaves
- Matrix system fixed with appropriate fasteners (see section 1.3) supplied by the Certificate holder
- Therma-quilt insulation laid continuously from ridge to eaves with tight abutments at roll ends
- external profile type CA 32 1000R and fasteners, side and end laps sealed with appropriate Therma-strip (see section 1.3) with vented eaves and ridge foam fillers.

Figure 3 Twin-Therm Roof System

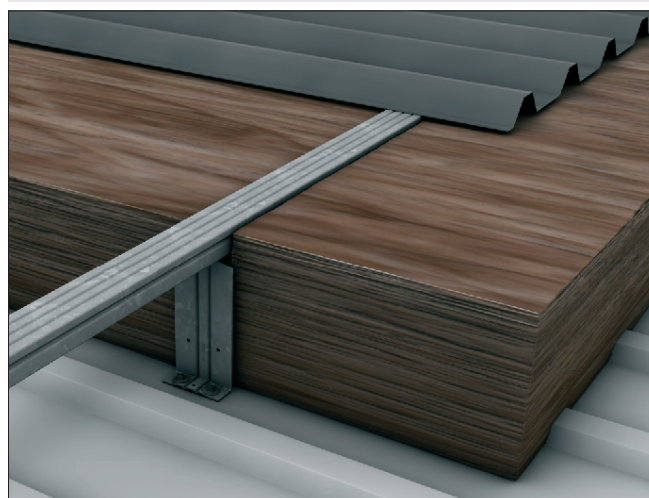

1.5 Customised accessories are also available from the Certificate holder but are outside the scope of this Certificate.

1.6 Openings in rooflights and through fittings can be incorporated into the Twin-Therm system, but are outside the scope of this Certificate.

1.7 Quality control includes checks on:

incoming material

- dimensions
- chemical composition
- mechanical properties
- coating thicknesses.

finished panels⁽¹⁾

- dimensional accuracy
- rolling damage to coatings
- fixability.

(1) These checks are carried out regularly.

2 Delivery and site handling

2.1 Detailed guidance on transportation, handling and storage is available from the Certificate holder.

2.2 The roof and liner sheets are delivered in banded bundles (sequential packaging is available) and should be handled carefully when offloading by fork-lift to avoid damage. Edges should be protected and soft, wide slings used when hoisting system panels into position. Lifting beams must be used when moving sheets longer than 8 m.

2.3 Individual sheets should be handled with care to prevent damage to the surface finish, the edges or corners. Damaged sheets should not be installed. Further information is available from the Certificate holder.

2.4 The roof and liner sheets and their accessories should be stored under cover in the original packing and in a dry, well-ventilated position. Roof and liner sheets should be kept away from building activities where contamination by lime or cement would cause staining.

2.5 When stacked on site, packing between sheets should be aligned vertically to ensure that the weight is transmitted directly through the packs and not the sheets. Sheets should be kept clear of the ground and stacked with a slight fall to shed any moisture that may penetrate the covers. Stacked sheets should be protected by tarpaulins or plastic covers, held clear of the stacked material to allow ventilation.

2.6 The profiled sheets and insulation display CE marking.

Assessment and Technical Investigations

The following is a summary of the assessment and technical investigations carried out on the Twin-Therm Roof System.

Design Considerations

3 General

3.1 The Twin-Therm Roof System is satisfactory for use on buildings as a structural roof system, with slopes from 3° to 60°, where access is available only for maintenance and repair. Standard sheets are used on curved roofs of radii from 45 m to 130 m, and pre-curved sheets on roofs of radii between 20 m and 45 m; sheet lengths should be such that end laps will have a minimum slope of 3°.

3.2 The system can be fixed to steel, concrete or timber purlins. However, the design information given in this Certificate is relevant only to fixing to mild steel purlins. Advice from the Certificate holder should be sought to determine the type of fasteners and design data required.

3.3 If architectural features and rooflights are required, in common with all metal roofs, special care and attention is necessary to ensure correct detailing and installation.

4 Practicability of installation

The system is designed to be installed by a competent general builder, or a contractor, experienced with this type of system.

5 Structural performance

 5.1 The roof will have adequate strength and stiffness to sustain the specified loads when the system is designed in accordance with this Certificate. Load/span values for the system incorporating CA LT 17 1000S or CA 32 1000RL liners with CA 32 1000R external profile are given in Table 2.

Table 2 Maximum working loads⁽¹⁾ to ⁽⁹⁾ limited by Matrix system fixed to 1.5 mm Z45 steel purlins

Bracket centres (mm)	Loading	Permissible loading (kN·m ⁻²)						
		Purlin span (m)						
		0.6	0.8	1.0	1.2	1.4	1.6	1.8
600 ⁽¹⁰⁾	Imposed	6.56	5.44	4.36	3.41	2.70	2.20	1.82
	Suction	6.73	5.66	4.55	6.52	2.79	2.27	1.89
800	Imposed	5.44	4.08	3.27	2.72	2.33	2.04	1.81
	Suction	6.50	4.88	3.90	3.25	2.79	2.44	1.89
1000	Imposed	4.36	3.27	2.61	2.18	1.87	1.63	1.45
	Suction	4.59	3.45	2.76	2.30	1.97	1.72	1.53
1200 ⁽¹¹⁾	Imposed	2.80	2.65	2.40	1.70	1.55	1.41	1.26
	Suction	4.28	3.28	2.62	2.18	1.87	1.64	1.36

(1) All loads are assumed to be applied uniformly and apply to multiple-span conditions, ie three spans or more.

(2) The self-weight of the external sheeting has been taken into account in the above loadings.

(3) Deflection limits are $L/90$ (wind suction loads) and $L/200$ (imposed loads), where L = span.

(4) The following load factors have been taken into account in the design capacity of the Matrix system:

- dead load 1.35
- snow load 1.50
- wind load 1.50
- dead load (restraining wind uplift) 1.00
- attachment resisting wind uplift 2.00

(5) All spans are assumed to be equal to or within 15% of the largest span.

(6) The above imposed loadings are applicable for sheets with brackets up to 300 mm high.

(7) For other loading conditions, the Certificate holder's advice should be sought.

(8) Structural design of all fasteners must be in accordance with the Certificate holder's recommendations.

(9) Load-span values are determined from both test and calculation.

(10) Where 600 mm bracket centres are used, six fasteners are required to fix the CA 32 1000R external sheets. Where bracket centres greater than 600 mm are used, three fixings per external sheet suffice.

(11) With CA LT 17 1000S liner panels, bracket spacing should be 1200 mm and with CA 32 1000RL liner panel, 1167 mm.

5.2 When evaluating the design loads, wind loads must be calculated in accordance with the recommendations of BS EN 1991-1-4 : 2005, and imposed snow loads must be calculated in accordance with the recommendations of BS EN 1991-1-3 : 2003.

5.3 On each installation, checks must be made by a suitably qualified structural engineer on:

- design requirements
- evaluation of the various design loads (dead, imposed and wind) on both the outside and inside surfaces of the roof system
- permissible load values are within those given in Table 2
- the adequacy of the fasteners between the external sheet and the Matrix spacer system, based on the data given in Table 2
- the adequacy of the fasteners between the Matrix system and the main purlin, and hence the acceptable spacing for the Matrix spacer system based on the strength data given in Table 2.

5.4 Crawling boards or purpose walkways should be provided over CA LT 17 1000S lining sheets during installation.

5.5 Liner sheets of type CA 32 1000RL or external sheets of type CA 32 1000R are capable of withstanding normal foot traffic and impact during normal handling, installation and service. If damaged during use, they should be replaced (see section 1.5.1).

6 Weathertightness

 6.1 When installed in accordance with the manufacturer's instructions (see Certificate holder's *Twin-Therm Installation Guide and Component Specification*) and this Certificate, the ridge, eaves, verge details and roof sheets will be weatherproof, with respect to rain and wind-driven moisture, when used on roofs with slopes from 3° to 60° (for curved roofs with end lap slopes greater than 3°), and within exposure conditions related to the recommended maximum design wind pressures given in section 5.

6.2 The weathertightness of the system will not be adversely affected by normal service deflections.

7 Thermal performance

 7.1 The thermal performance of each building incorporating the roof system must be evaluated in accordance with the relevant national Building Regulations, and is the responsibility of the overall designer of the building.

7.2 Typical U values for roofs, calculated in accordance with BS EN ISO 10211 : 2007, are given in Tables 3 and 4.

Table 3 U values⁽¹⁾⁽²⁾ – CA LT 17 1000S liner panel

Cavity depth (mm)	Insulation thickness (mm)	U value (W·m ⁻² ·K ⁻¹)						
		Purlin spacing (m)						
		0.6	0.8	1.0	1.2	1.4	1.6	1.8
80	TQ80	0.57	0.55	0.53	0.52	0.52	0.51	0.51
100	TQ100	0.45	0.44	0.43	0.42	0.42	0.41	0.41
120	TQ120	0.38	0.37	0.36	0.35	0.35	0.34	0.34
140	TQ140	0.33	0.31	0.31	0.30	0.30	0.30	0.29
160	TQ160	0.29	0.28	0.27	0.27	0.26	0.26	0.26
180	TQ180	0.25	0.25	0.24	0.24	0.23	0.23	0.23
200	TQ200	0.23	0.22	0.22	0.21	0.21	0.21	0.21
220	TQ220	0.21	0.20	0.20	0.19	0.19	0.19	0.19
240	TQ240	0.19	0.18	0.18	0.18	0.18	0.17	0.17
260	TQ260	0.18	0.17	0.17	0.16	0.16	0.16	0.16
280	TQ280	0.16	0.16	0.16	0.15	0.15	0.15	0.15
300	TQ300	0.15	0.15	0.14	0.14	0.14	0.14	0.14

(1) Insulation is normally supplied with a $\lambda_{90/90}$ value of 0.040 W·m⁻¹·K⁻¹ and compressed to suit the cavity.

(2) Typically, bracket spacing is 1200 mm.

Table 4 U values⁽¹⁾⁽²⁾ – CA 32 1000RL liner panel

Cavity depth (mm)	Insulation thickness (mm)	U value (W·m ⁻² ·K ⁻¹)						
		Purlin spacing (m)						
		0.6	0.8	1.0	1.2	1.4	1.6	1.8
80	TQ80	0.67	0.64	0.62	0.61	0.60	0.59	0.59
100	TQ100	0.51	0.49	0.48	0.47	0.46	0.46	0.46
120	TQ120	0.42	0.40	0.39	0.39	0.38	0.38	0.37
140	TQ140	0.35	0.34	0.33	0.33	0.32	0.32	0.32
160	TQ160	0.31	0.29	0.29	0.28	0.28	0.28	0.28
180	TQ180	0.27	0.26	0.25	0.25	0.25	0.25	0.24
200	TQ200	0.24	0.23	0.23	0.22	0.22	0.22	0.22
220	TQ220	0.22	0.21	0.21	0.20	0.20	0.20	0.20
240	TQ240	0.20	0.19	0.19	0.19	0.18	0.18	0.18
260	TQ260	0.18	0.18	0.17	0.17	0.17	0.17	0.17
280	TQ280	0.17	0.16	0.16	0.16	0.16	0.16	0.15
300	TQ300	0.16	0.15	0.15	0.15	0.15	0.14	0.14

(1) Insulation is normally supplied with a $\lambda_{90/90}$ value of 0.040 W·m⁻¹·K⁻¹ and compressed to suit the cavity.

(2) Typically, bracket spacing is 1167 mm.



7.3 The roof system contributes to meeting the requirements of the national Building Regulations.

7.4 The effect of thermal bridging at the junctions between the systems and other building elements, eg walls, and around openings such as rooflights, must be minimised. The performance of these junctions will be dependent upon building elements not covered by this Certificate. A suitable assessment of all junction details should be carried out.

8 Risk of condensation



8.1 In common with all metal roof constructions, there is a risk of condensation. This can arise either as surface condensation at thermal bridging or interstitial condensation within the roof construction.

Surface condensation

8.2 The internal temperature at which surface condensation will occur on the internal surfaces of the roof is dependent on both the internal relative humidity and the external temperature. For roof constructions comprising cavities from 80 mm to 300 mm deep, it has been shown by computer modelling that the risk of condensation occurring on the internal surfaces (including those below the thermal bridges formed by the Matrix system) is negligible.

8.3 In buildings likely to experience sustained high internal relative humidities, there is a risk of condensation forming on and around the fixing screws penetrating the purlin. The designer should anticipate the areas of the structure that could be at risk from local sources of humidity and take the necessary measures to prevent any such problems.

Interstitial condensation

8.4 The system has been favourably assessed for the risk of damage due to interstitial condensation. The assessments assume that the following details have been observed and will not be valid without these details in place:

- liner panel laps are adequately sealed — this is achieved by using 6 mm by 5 mm or 9 mm by 3 mm Therma-strip sealant for end laps and 50 mm wide Therma-foil Plus for the side laps
- the ribs of the CA 32 1000R profile are ventilated by air passing between open areas at the eaves and the ridge, with an equivalent open area of 3680 mm² per metre.

8.5 From computer modelling, it is predicted that, for buildings in internal humidity classes 1 to 4 (see Table 5), interstitial condensation is unlikely to be a significant problem under the normal climatic conditions experienced in the UK, provided the liner remains adequately sealed (see section 15.1).

Table 5 Internal humidity classes

Humidity class ⁽¹⁾	Building types
1	Storage areas
2	Offices, shops
3	Dwellings with low occupancy
4	Dwellings with high occupancy, sports halls, kitchens, canteens; buildings heated with un-flued gas heaters
5	Special buildings, eg laundries, breweries, swimming pools

(1) As referenced in BS EN ISO 13788 : 2002 and BS 5250 : 2002.

8.6 For buildings in internal humidity class 5 and in buildings or areas of a building with special internal design conditions, a hygrothermal assessment of the proposed roof system should be undertaken using the guidance given in BS 6229 : 2003, BS 5250 : 2002 and BS 5925 : 1991 to establish whether special provisions, such as additional ventilation or air conditioning with the building, are required to maintain the internal conditions within acceptable limits. Advice should be sought from the Certificate holder.

9 Airtightness



9.1 To minimise air leakage, the liner must be installed and sealed in accordance with the Certificate holder's recommendations at all laps, penetrations and around the perimeter. The standard Twin-Therm construction, correctly installed, has been shown to be capable of achieving a level of performance equal to or less than 3 m³·h⁻¹·m⁻² when tested after installation at a pressure differential of 50 Pa.



9.2 Completed buildings in England and Wales are subject to pre-completion testing for airtightness in accordance with the requirements of Approved Documents L1A and L2A, section 20B.



9.3 Completed buildings in Scotland are only subject to the 2007 Accredited Construction Details for airtightness testing if the target air permeability of the building is less than 10 m³·h⁻¹·m⁻² and 15 m³·h⁻¹·m⁻² and the designer does not wish to use the 15 m³·h⁻¹·m⁻² default figure in the building, in accordance with Mandatory Standard 6.2, clauses 6.2.5⁽¹⁾ and 6.2.6⁽²⁾.

(1) Technical Handbook (Domestic).

(2) Technical Handbook (Non-Domestic).



9.4 In Northern Ireland, completed buildings are subjected to pre-completion testing for airtightness in accordance with the requirements of Technical Booklets F1, Sections 2.46 to 2.54, and F2, Sections 2.57 to 2.61.

10 Performance in relation to fire



10.1 The external sheets of the system have a notional designation of AA (national class) and B_{ROOF(t4)} (European class) in accordance with Approved Document B (Volume 1), Appendix A, Table A5 (England and Wales) and Technical Booklet E, Table 4.6 (Northern Ireland), and may be used as a roof covering within six metres of any boundary.



10.2 The external sheets of the system have a 'low vulnerability' risk rating and, therefore, are unrestricted under Mandatory Standard 2.8, clause 2.8.1⁽¹⁾⁽²⁾.

(1) Technical Handbook (Domestic).

(2) Technical Handbook (Non-Domestic).



10.3 When tested to BS 476-6 : 1989, the external sheets have an index of performance (I) of ≤ 12 and a sub-index (i) of ≤ 6. When tested to BS 476-7 : 1997, the external sheets achieved Class 1. The product, therefore, has a Class 0 or 'low risk' surface as defined in the various national Building Regulations.

10.4 When tested to BS 476-4 : 1970, Therma-quilt insulation is classified as non-combustible as defined in the national Building Regulations.

10.5 The underside of the liner panels is deemed to have a Class 0 or 'low risk' internal surface spread of flame as defined in the national Building Regulations.

11 Acoustic performance

11.1 Where sound insulation properties are required, the guidance given in BS 8233 : 1999 should be followed. Particular care should be taken to ensure that the roof construction is properly sealed at wall junctions.

11.2 From an airborne sound insulation test conducted on a Twin-Therm roof construction (TP15) in accordance with BS EN ISO 140-3 : 1995, and rated in accordance with BS EN ISO 717-1 : 1997, the weighted sound reduction index [$R_w(C;C_{tr})$] was found to be 42 (-4; -11) dB. The test was made on a construction consisting of:

- type CA 32 1000R HPS200 Ultra, steel profile, nominally 0.7 mm thick and joints stitched at 450 mm centres
- 180 mm thick Therma-quilt glassfibre insulation
- 180 mm deep Matrix system fixed at 1200 mm centres
- type CA LT 17 1000S liner sheet, nominally 0.4 mm thick. Side laps in sheets, sealed using 9 mm by 3 mm Therma-strip sealant. The perimeter of the test aperture was sealed with butyl mastic.

12 Maintenance and repair

 12.1 Roofs constructed using the product should be regularly inspected for accidental damage and build-up of dirt and debris. Damage must be repaired and accumulated dirt and debris removed. The frequency of inspections will depend on the environment and use of the building. Typically, roofs will be inspected on completion, 12 months after completion and once every three years thereafter.

12.2 In industrial or coastal areas it may be necessary to clean the installation periodically by hosing with water and a neutral detergent to remove potentially corrosive deposits and restore its appearance. It may be necessary to clean soffits in any environment.

12.3 Damaged sheets can be removed and replaced. Small damaged areas of the coated material may be re-coated using the appropriate touch-up paint system. Full details of methods for removal and replacement can be obtained from the Certificate holder.

12.4 If regular access to the roof is necessary (eg for maintenance of equipment), appropriate access and safety precautions should be provided. Such details are outside the scope of this Certificate.

13 Durability

 13.1 The durability of type CA 32 1000R profile will depend upon the coating material, the immediate environment, aspect faced, and use. Colour changes will be slight and uniform in any one elevation.

13.2 Maintenance painting may be necessary to restore the appearance of coated sheets, or to extend their design life, and should be considered at the intervals specified in Table 6.

Table 6 Minimum service (decorative) life⁽¹⁾ (years)

Sheet material ⁽²⁾⁽³⁾	Rural or suburban	Industrial or coastal
Colorcoat HPS200 Ultra, signature colours	25	20
Colorcoat HPS200 Ultra, classics and matts	25	20
Colorcoat Prisma, solid and metallic colours	30	15
Colorcoat Prisma, matt colours	30	15
Colorcoat LG (CD1)	25	20
Colorcoat LG (CD2)	15	10
Colorcoat Verso (CD1)	30	25
Colorcoat Verso (CD2)	20	15
Colorcoat PVDF	15	10

(1) Minimum service life is the period until first maintenance painting is required.

(2) Full details on durability are given in BBA Certificate 91/2717.

(3) Colorcoat HPS200 Ultra, Colorcoat Prisma, Colorcoat LG, Colorcoat Verso and Colorcoat PVDF are all registered trademarks of Tata Steel UK Limited.

13.3 In aggressive environments, eaves edge corrosion of coated steel sheets can be minimised by overpainting.

13.4 A planned maintenance cycle (see section 12) should be introduced if an extended design life is required. The Certificate holder can recommend a suitable system for maintenance painting.

14 General

14.1 Installation of the Twin-Therm Roof System should be carried out by suitably competent personnel in accordance with the Certificate holder's *Twin-Therm Installation Guide and Component Specification*. The Certificate holder can provide guidance for sub-contractors who have not fixed the system previously. All site installations must be carried out by, or under the direct supervision of, personnel who have suitable knowledge or experience of the system and its components. Guidance can be obtained from the Certificate holder.

14.2 The contractor may sub-divide the roof construction into processes (eg lining, insulation, top sheets and flashing) able to be completed within one working day. Alternatively, the whole roof area can be covered with the liner panels and the roof installed as described in the Certificate holder's *Twin-Therm Installation Guide and Component Specification*.

14.3 Roof surfaces can be slippery when wet and the designer, contractor, and others should take this into consideration when they prepare the Health and Safety Plan for the contract.

14.4 The system utilises a standard visible throughfix sheet fixing and, apart from a screw-gun for ensuring the correct torque on all fasteners, special tools are not required.

14.5 The typical constructional details have been assessed by the BBA as adequately maintaining insulation continuity. The Certificate holder can supply psi values of specific details of a project, but this aspect is outside the scope of this Certificate and is entirely the responsibility of the Certificate holder.

15 Procedure

15.1 The liner panels are fixed to the purlins in accordance with the Certificate holder's *Twin-Therm Installation Guide and Component Specification*, with one run of Therma-strip (9 mm by 3 mm or 6 mm by 5 mm) for all end laps, and one run of Therma-foil Plus for all side laps. Swarf or debris is removed from the panels. Solid flame-retarded polyethylene fillers are introduced at details, such as eaves, hips and valleys, to ensure continuity of the vapour control layer (see Figures 4 and 5). Damaged panels should be replaced and sealed in the manner described above.

15.2 Therma-crank ridge liners should be used where appropriate, fixed and sealed to the liner panels in the manner described in section 15.1 (see Figures 4 and 5).

Figure 4 Installation of steel liner panels

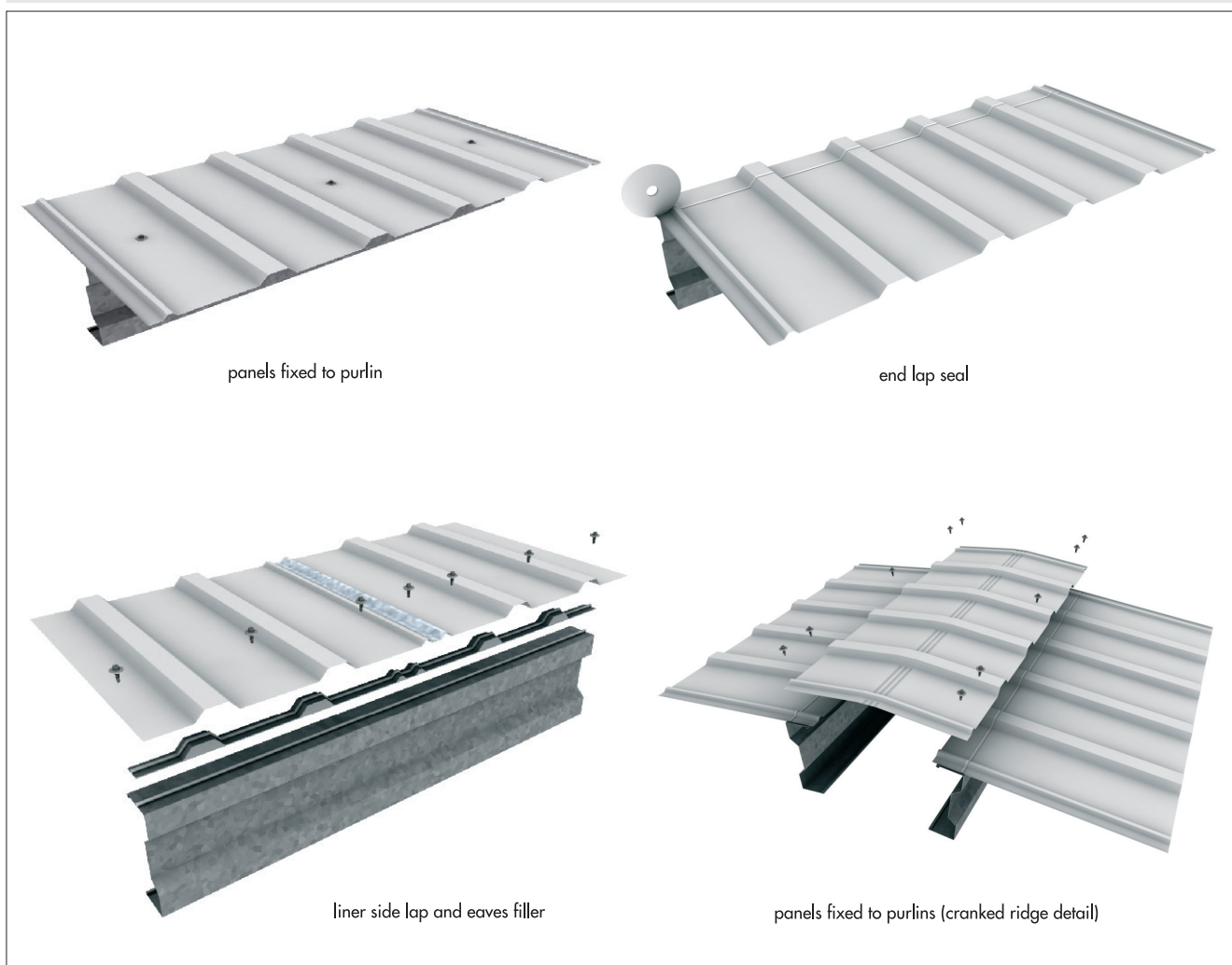
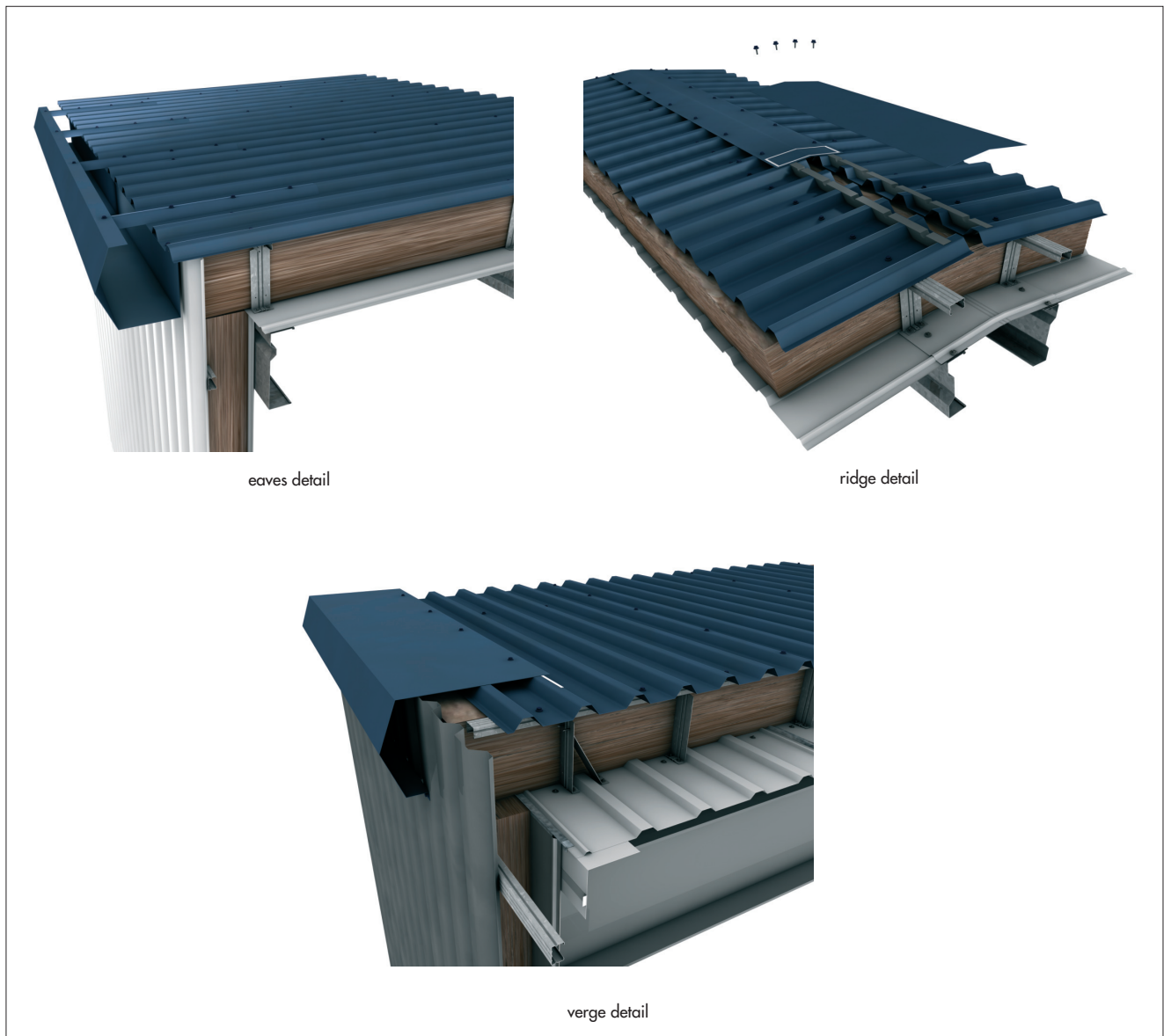
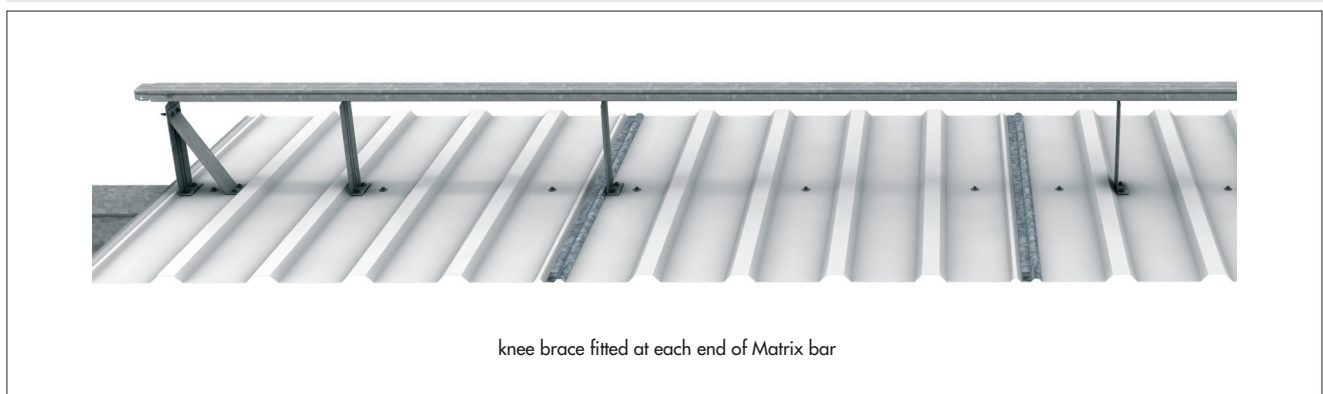

Figure 5 Typical details



15.3 The Matrix system is fixed through the liner panels to the roof purlin using the appropriate fasteners (see Figure 6).

Figure 6 Detail of fixing Matrix system



15.4 The Therma-quilt insulation is laid in one continuous run from ridge to eaves (where lengths are insufficient to enable this, a firm abutment is required).

15.5 The external roof sheet type CA 32 1000R is fixed to the Matrix system in accordance with the Certificate holder's *Twin-Therm Installation Guide and Component Specification* by three⁽¹⁾ self-drilling fasteners per sheet per Matrix bar (located in the valleys of alternate corrugations), using the appropriate screw-gun and torque setting (see Figure 7). At ridge, eaves and external sheet end laps, six fasteners per sheet should be used (located in each valley).

(1) For high wind loads, additional fasteners may be required.

15.6 External sheets should be sealed by:

- end laps — two runs (typically 130 mm apart) of Therma-strip 6 mm by 5 mm (see Figure 7) positioned to suit the Certificate holder's recommendations
- side laps — by one run of Therma-strip 6 mm by 5 mm (see Figure 7)
- ridge and eaves — by one run of Therma-fill ventilated filler blocks; the material used depends on the location in the UK.

15.7 The side laps of the external sheets are fixed at a maximum spacing of 450 mm using the appropriate stitcher screw to ensure compression of the sealant when pulling the two sheets together. The stitcher screws are installed through the crown of the profile (see Figure 7).

Figure 7 Installing external weather-skin sheets

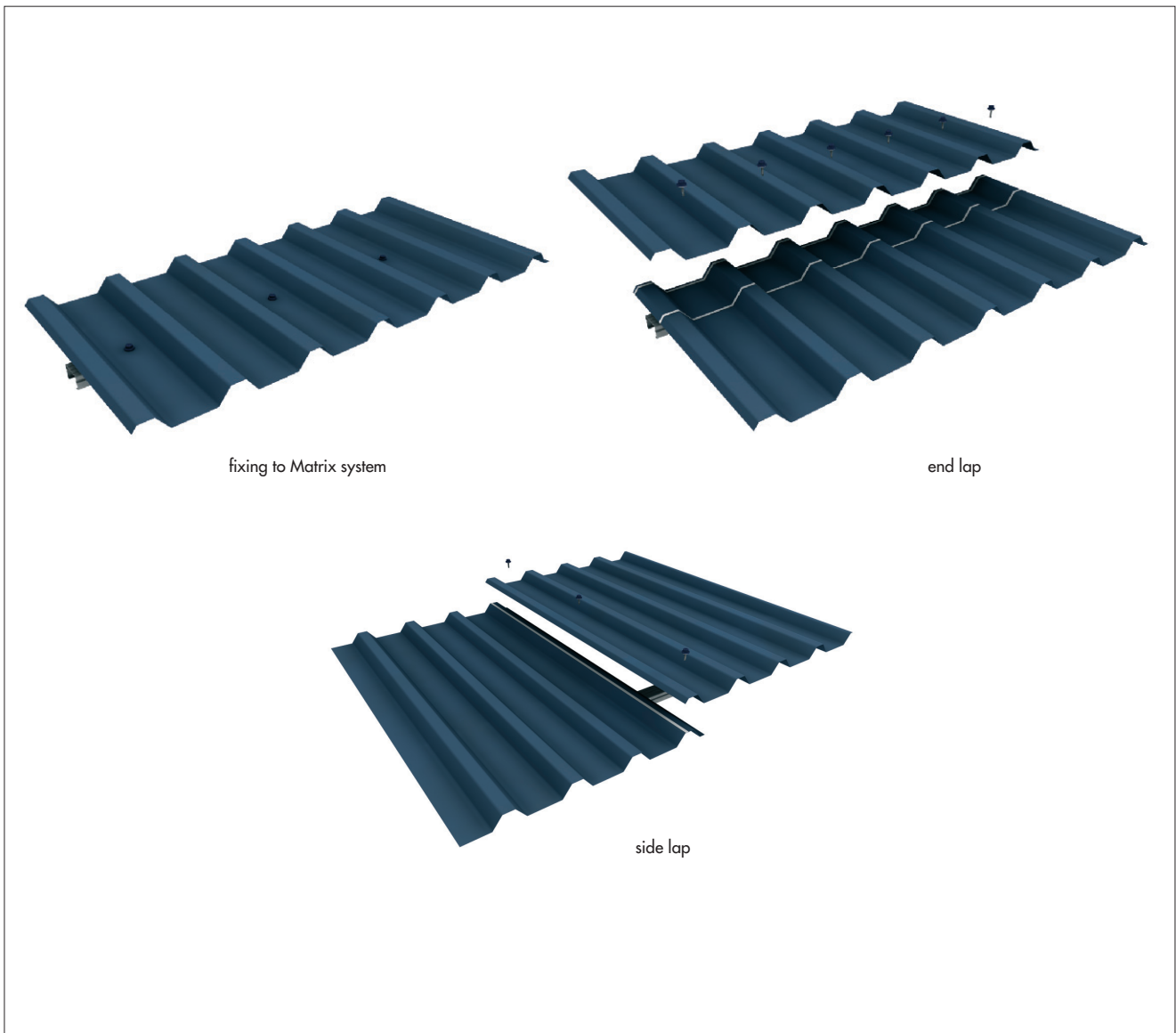

Technical Investigations

16 Tests

16.1 Independent tests were carried out to establish the acoustic performance of the Twin-Therm double-skin roof construction.

16.2 Tests were carried out on the system to establish:

- resistance to dead and imposed (snow) loading
- resistance to wind loading
- behaviour of fixings and profile under static and cyclic loading
- resistance to impact
- behaviour under concentrated loads.

17 Investigations

17.1 The manufacturing process was examined, including the methods adopted for quality control, and details of the quality and composition of the materials used were obtained.

17.2 An assessment was made of:

- structural adequacy of types CA 32 1000R profiles
- performance in fire
- practicability of installation
- condensation risk and thermal transmittance (evaluated by calculation)
- weathertightness of the roof sheets and joints.

17.3 Existing information, relating to the durability of the system and compatibility of materials in contact, has been examined.

17.4 A visit was made to a site to assess the practicability of installation.

Additional Information

CA Building Products has been assessed by the Health and Safety Executive (HSE) as being capable of carrying out the necessary tests to establish a non-fragile assembly for the system in accordance with HSE document ACR(M)001 : 2005. This aspect is outside the scope of this Certificate and is entirely the responsibility of the Certificate holder, from whom further details are available.

Bibliography

- BS 476-4 : 1970 *Fire tests on building materials and structures — Non-combustibility test for materials*
- BS 476-6 : 1989 *Fire tests on building materials and structures — Method of test for fire propagation for products*
- BS 476-7 : 1997 *Fire tests on building materials and structures — Method of test to determine the classification of the surface spread of flame of products*
- BS 5250 : 2002 *Code of practice for control of condensation in buildings*
- BS 5925 : 1991 *Code of practice for ventilation principles and designing for natural ventilation*
- BS 6229 : 2003 *Flat roofs with continuously supported coverings — Code of practice*
- BS 8233 : 1999 *Sound insulation and noise reduction for buildings — Code of practice*
- BS EN 1991-1-3 : 2003 *Eurocode 1 : Actions on structures — General actions — Snow loads*
- BS EN 1991-1-4 : 2005 *Eurocode 1 : Actions on structures — General actions — Wind actions*
- BS EN 10346 : 2009 *Continuously hot-dip coated steel flat products — Technical delivery conditions*
- BS EN 13162 : 2008 *Thermal insulation products for buildings — Factory made mineral wool (MW) products — Specification*
- BS EN 13172 : 2008 *Thermal insulation products — Evaluation of conformity*
- BS EN 14782 : 2006 *Self-supporting metal sheet for roofing, external cladding and internal lining. Product specification and requirements*
- BS EN ISO 140-3 : 1995 *Acoustics — Measurement of sound insulation in buildings and of building elements — Laboratory measurement of airborne sound insulation of building elements*
- BS EN ISO 717-1 : 1997 *Acoustics — Rating of sound insulation in buildings and of building elements — Airborne sound insulation*
- BS EN ISO 13788 : 2002 *Hygrothermal performance of building components and building elements — Internal surface temperature to avoid critical surface humidity and interstitial condensation — Calculation methods*

18 Conditions

18.1 This Certificate:

- relates only to the product/system that is named and described on the front page
- is issued only to the company, firm, organisation or person named on the front page — no other company, firm, organisation or person may hold or claim that this Certificate has been issued to them
- is valid only within the UK
- has to be read, considered and used as a whole document — it may be misleading and will be incomplete to be selective
- is copyright of the BBA
- is subject to English Law.

18.2 Publications, documents, specifications, legislation, regulations, standards and the like referenced in this Certificate are those that were current and/or deemed relevant by the BBA at the date of issue or reissue of this Certificate.

18.3 This Certificate will remain valid for an unlimited period provided that the product/system and its manufacture and/or fabrication, including all related and relevant parts and processes thereof:

- are maintained at or above the levels which have been assessed and found to be satisfactory by the BBA
- continue to be checked as and when deemed appropriate by the BBA under arrangements that it will determine
- are reviewed by the BBA as and when it considers appropriate.

18.4 The BBA has used due skill, care and diligence in preparing this Certificate, but no warranty is provided.

18.5 In issuing this Certificate, the BBA is not responsible and is excluded from any liability to any company, firm, organisation or person, for any matters arising directly or indirectly from:

- the presence or absence of any patent, intellectual property or similar rights subsisting in the product/system or any other product/system
- the right of the Certificate holder to manufacture, supply, install, maintain or market the product/system
- individual installations of the product/system, including their nature, design, methods, performance, workmanship and maintenance
- any works and constructions in which the product/system is installed, including their nature, design, methods, performance, workmanship and maintenance
- any loss or damage, including personal injury, howsoever caused by the product/system, including its manufacture, supply, installation, use, maintenance and removal.

18.6 Any information relating to the manufacture, supply, installation, use, maintenance and removal of this product/system which is contained or referred to in this Certificate is the minimum required to be met when the product/system is manufactured, supplied, installed, used, maintained and removed. It does not purport in any way to restate the requirements of the Health and Safety at Work etc. Act 1974, or of any other statutory, common law or other duty which may exist at the date of issue or reissue of this Certificate; nor is conformity with such information to be taken as satisfying the requirements of the 1974 Act or of any statutory, common law or other duty of care.