

Every effort has been made to ensure the details in this publication are correct at the time of printing. CA Group accepts no responsibility for errors included in this publication. To ensure that products are suitable for your project refer to CA Building Products' Technical Department.
 CA Group Registered Trademarks: Twin-Therm™, River-Therm™, Plano-Therm™, Solar-Therm™, SolarWall Metal Solar Cladding System™, CA Building Products FireTight™, Cascade™.

CASCADE
PREMIER
 Rainwater Management System

Evenwood Industrial Estate
 Copeland Road
 Evenwood
 Co Durham
 DL14 9SF
 Tel: 01388 834 242
 Fax: 01388 834 711
 www.cagroup.ltd.uk



CASCADE
PREMIER
 Rainwater Management System



CASCADE PREMIER

Rainwater Management System

The first in the CA range of membrane lined rainwater management systems, Cascade™ Premier delivers the quick and simple installation benefits of Hot Air welding techniques.

With a complete portfolio of fully compatible accessories, full design and calculation service and classroom based or on-site training available, the Cascade™ system offers bespoke solutions to most rainwater management design issues.

The membrane supplied within the system is pre-laminated under the most rigorous Quality Assurance conditions, allowing the entire system to be supplied complete with the well established CA Building Products guarantee. The membrane delivers the additional comfort of comprehensive BBA Agrément Certification and is highly puncture-resistant.

Structurally designed to the exacting requirements of BS 5950:parts 5 & 6, the Cascade™ Premier system utilises high tensile precision steels in its manufacture. Expansion and contraction issues – along with steelwork tolerances – can be accommodated within the construction.

Girths of up to 1450mm are available.

Full system design and technical backup is available, as you would expect from a CA Building Products system, and final site inspections can be arranged on request.

- Fully compliant with building regulations.
- Comprehensive accessory package.
- High tensile steel substrates.
- Full design and calculation service to BS EN 12056-3:2000.
- Complete range of junctions available.
- Fully walkable.

System Enhancements

The Cascade™ Premier range can deliver a series of additional benefits dependent on the product specified:

Cascade™ Premier – TE

This unique, patented, Thermal break solution offers exceptional Psi-values by radically reducing the gutters ability to act as a thermal conductor. The structural requirement for gutters means that they must rest on the purlins – which in turn means that they are potential 'heat sink' junctions – running from the warm interior of the building to the cold exterior. The Cascade™ Premier – TE reduces the amount of heat which can escape at this junction without compromising structural integrity.

Cascade™ Premier FireTight – TE

Delivers all of the benefits of the Premier range, with the added comfort of Rock-Fibre insulation, to give a logically FireTight Rainwater system.

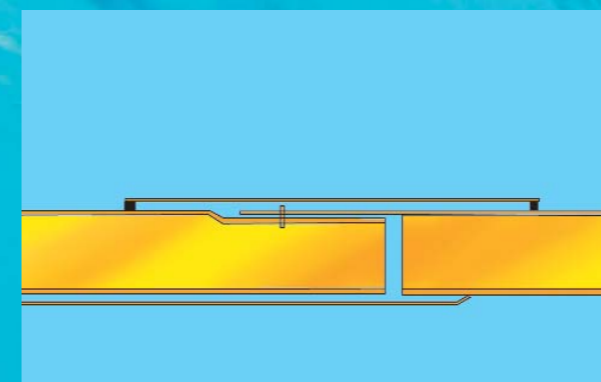

Simple jointing details allow for quick installation and cater for expansion and contraction.

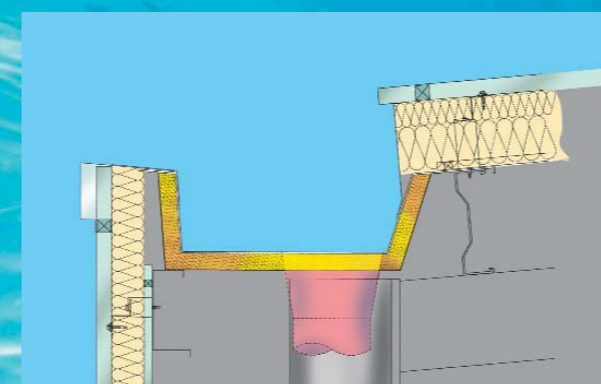

A comprehensive detailing service assists designers in ensuring the best project-specific solution.

Rainwater Pipes

The Cascade™ system allows specifiers to select their entire rainwater management scheme from CA Building Products, as it incorporates a high capacity rainwater pipe range. This downpipe range has been developed to blend perfectly with the Cascade™ range, and is available in 110mm, 160mm and 200mm diameter, in either plain ended or single socket format. High quality PVC fittings, including bends, branches, access pipes and clips ensure the systems retains the adaptability essential in the planning of an industrial rainwater system.

At ground level, the rainwater system is fully compatible with most underground drainage systems, meeting the requirements of the relevant British Standards.



The system is available in a comprehensive range of colours.

